

instructions

KM260 series

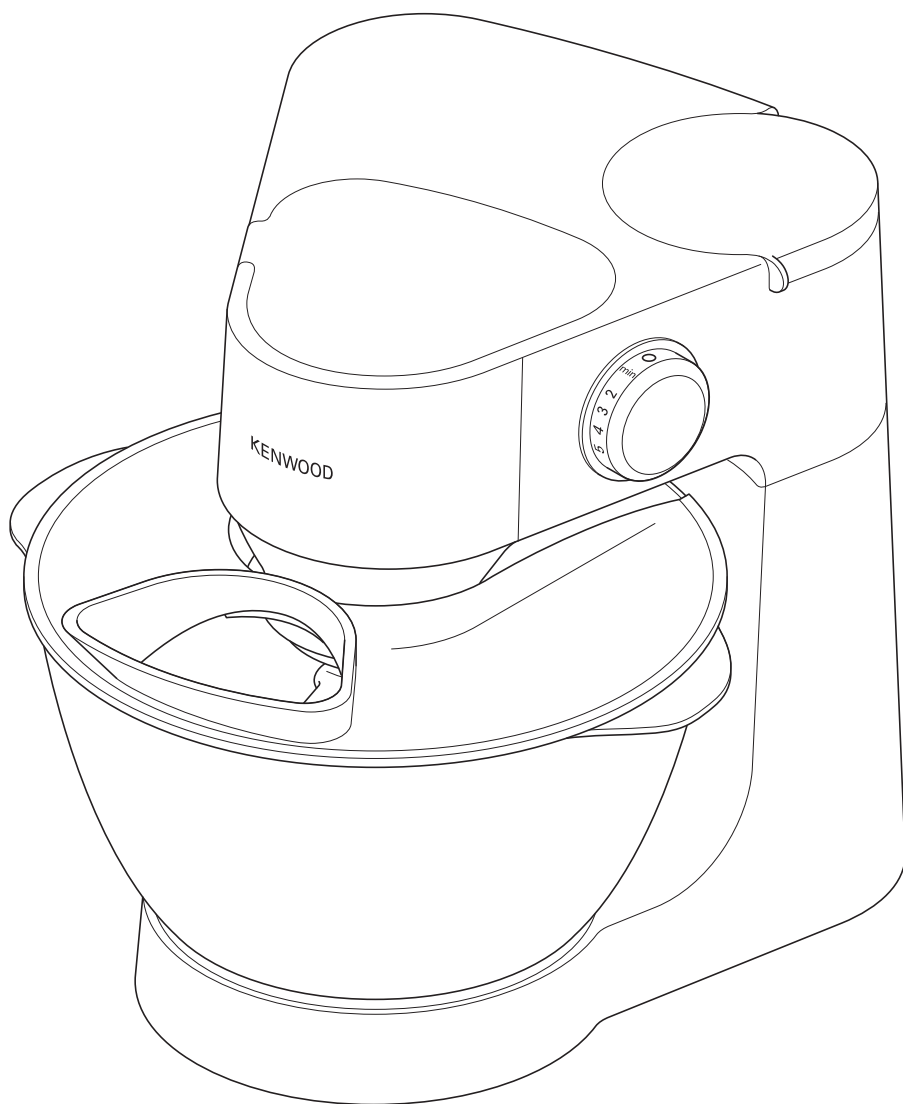

KENWOOD

know your Kenwood kitchen machine

safety

- Switch off and unplug before fitting or removing tools, after use and before cleaning.
- Never let the cord hang down where a child could grab it.
- Keep your fingers away from moving parts and fitted tools. Never put your fingers etc in the hinge mechanism.
- Never leave the machine on unattended.
- Never use a damaged machine. Get it checked or repaired: see 'service and customer care', page 5.
- Never let the power unit, cord or plug get wet.
- Never use an unauthorised attachment or more than one attachment at a time.
- When using an attachment, read the safety information that comes with it.
- Never exceed the maximum capacities on page 5.
- Take care when lifting this appliance. Ensure the head is locked and that the bowl, tools, and cord are secure before lifting.
- This appliance is not intended for use by persons (including children) with reduced physical, sensory or mental capabilities, or lack of experience and knowledge, unless they have been given supervision or instruction concerning use of the appliance by a person responsible for their safety.
- Children should be supervised to ensure that they do not play with the appliance.
- Only use the appliance for its intended domestic use. Kenwood will not accept any liability if the appliance is subject to improper use, or failure to comply with these instructions.

before plugging in

- Make sure your electricity supply is the same as the one shown on the underside of your machine.
- The wires in the cord are coloured as follows:
Blue = Neutral,
Brown = Live.
- The appliance must be protected by a 13A approved (BS1362) fuse.

Note:

- For non-rewireable plugs the fuse cover MUST be refitted when replacing the fuse. If the fuse cover is lost then the plug must not be used until a replacement can be obtained. The correct fuse cover is identified by colour and a replacement may be obtained from your Kenwood Authorised Repairer (see Service).
- If a non-rewireable plug is cut off it must be DESTROYED IMMEDIATELY. An electric shock hazard may arise if an unwanted non-rewireable plug is inadvertently inserted into a 13A socket outlet.
- This appliance conforms to EC directive 2004/108/EC on Electromagnetic Compatibility and EC regulation no. 1935/2004 of 27/10/2004 on materials intended for contact with food.

important - UK only

before using for the first time

- 1 Remove all packaging.
- 2 Push excess cord in the cord storage compartment in the back of the mixer.
- 3 Wash the parts: see 'care and cleaning', page 8.

know your Kenwood kitchen machine

- 1 medium speed outlet
- 2 high speed outlet
- 3 tool socket
- 4 head release lever
- 5 mixer head
- 6 bowl
- 7 on/off and speed switch
- 8 power unit
- 9 cord storage compartment
- 10 beater
- 11 dough hook with removable guard
- 12 whisk
- 13 splashguard

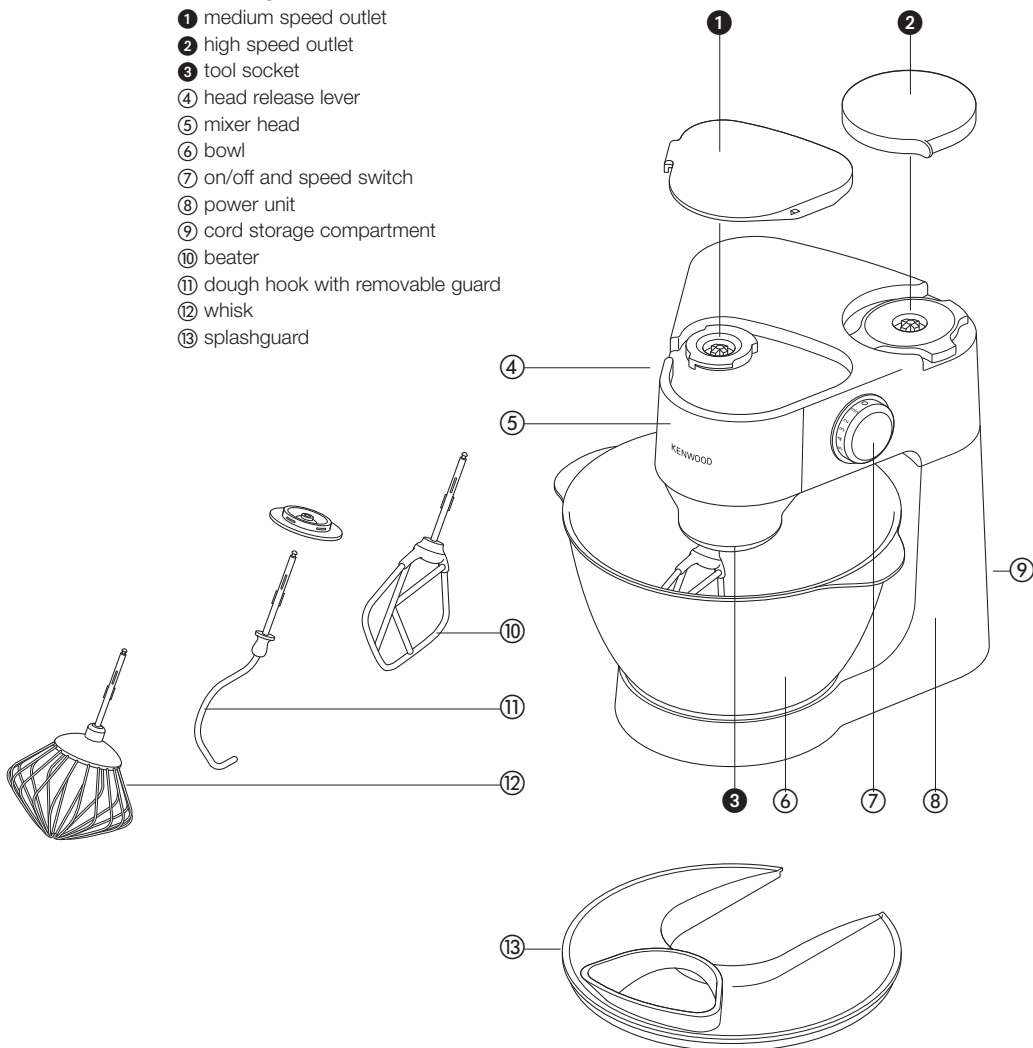

the mixer

the mixing tools and some of their uses

- beater ● For making cakes, biscuits, pastry, icing, fillings, éclairs and mashed potato.
- whisk ● For eggs, cream, batters, fatless sponges, meringues, cheesecakes, mousses, soufflés. Don't use the whisk for heavy mixtures (eg creaming fat and sugar) - you could damage it.
- dough hook ● For yeast mixtures.

to use your mixer

- 1 Press down on the head release lever **1** and raise the mixer head until it locks into position.
- to insert a tool
- 2 Select a tool and push into the tool socket **2**.
 - Always ensure the guard is fitted onto the shaft of the dough hook before inserting into the outlet. Once inserted fit the guard to the mixer outlet to prevent food ingress.
 - 3 Fit the bowl into the base and turn clockwise to lock into position **3**.
 - 4 Press down on the head release lever and lower the mixer head until it locks into position.
 - 5 Plug into the power supply then switch on and turn the speed switch to the desired setting. To switch off turn to '0'.
 - Switch to pulse P for short bursts
 - 6 Unplug from the power supply.
- to remove a tool
- 7 Raise the mixer head and whilst holding it steady, pull the tool from the outlet.

important ● Some movement of the mixer head is normal when mixing heavy loads such as bread dough.

- If the mixer head is raised during operation, the machine will stop working straight away. To re-start the mixer, lower the mixer head, turn the speed switch to the off position, wait a few seconds and then re-select the speed. The mixer should resume operating straight away.
- If for any reason power to the mixer is interrupted and the machine stops working, turn the speed switch to the off position, wait a few seconds and then re-select the speed. The mixer should resume operating straight away.
- **The mixer will not operate unless all the outlet covers are correctly fitted to the machine.**
- If you hear the machine labouring either switch off and remove some of the mixture or increase the speed.

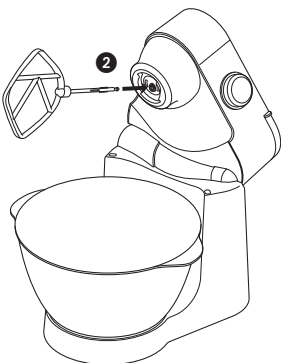

- hints
- Switch off and scrape the bowl with a spatula when necessary.
 - Eggs at room temperature are best for whisking.
 - Before whisking egg whites, make sure there's no grease or egg yolk on the whisk or bowl.
 - Use cold ingredients for pastry unless your recipe states otherwise.
 - When creaming fat and sugar for cake mixes, always use the fat at room temperature or soften it first.
 - Your mixer has been fitted with 'soft start' feature to minimise spillage. However if the machine is switched on with a heavy mixture in the bowl such as bread dough, you may notice that the mixer takes a few seconds to reach the selected speed.

points for bread making

- important
- Never exceed the maximum capacities stated - you will overload the machine.
 - Some movement of the mixer head is normal when mixing heavy loads such as bread dough.
 - The ingredients mix best if you put the liquid in first.
 - At intervals stop the machine and scrape the mixture off the dough hook.
 - Different batches of flour vary considerably in the quantities of liquid required and the stickiness of the dough can have a marked effect on the load imposed on the machine. You are advised to keep the machine under observation whilst the dough is being mixed; the operation should take no longer than 6-8 minutes.

speed switch

These are a guide only and will vary depending upon the quantity of mix in the bowl and the ingredients being mixed.

- beater
- **creaming fat and sugar** start on min gradually increasing to a higher speed
 - **beating eggs into creamed mixtures** use a medium to high speed
 - **folding in flour, fruit etc** use a low to medium speed
 - **all in one cakes** start on a low speed gradually increasing to a higher speed
 - **rubbing fat into flour** use a low to medium speed
- whisk
- gradually increase to maximum
- dough hook
- use a low to medium speed

maximum capacities

shortcrust pastry	450g flour weight
sponge cake (one stage mix)	1.6 Kg total mix
fruit cake mix	1.8 Kg total mix
bread dough	500g flour weight
egg whites	8

electronic speed sensor control

Your mixer is fitted with an electronic speed sensor control that is designed to maintain the speed under different load conditions, such as when kneading bread dough or when eggs are added to a cake mix. You may therefore hear some variation in speed during the operation as the mixer adjusts to the load and speed selected - this is normal.

to fit and use the splashguard

- 1 Fit the bowl into the base and add the ingredients.
 - 2 Fit the tool then lower the mixer head
 - 3 Fit the splashguard onto the bowl by sliding the cut away section around the mixer head 4.
 - 4 To remove the splashguard reverse the above procedure.
- During mixing, ingredients can be added directly to the bowl via the chute.

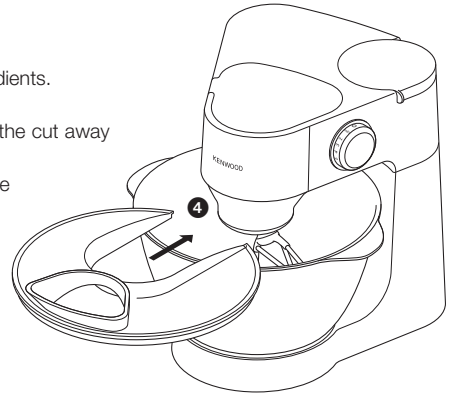

the attachments available

To buy an attachment not included in your pack, see service and customer care.

attachment attachment code

liquidiser ① 1.5 l acrylic **AT262**

mincer ② **AT261** comes with medium and coarse screens

food processing attachment ③ **AT264** comes with

- a knife blade
- b reversible thick slicer/shredder
- c reversible thin slicer/shredder
- d rasping plate (grates parmesan cheese and potato for German potato dumplings)
- e citrus juicer

optional attachments f thin (julienne style) chipper plate

g standard chipper plate

h extra coarse shredder plate

centrifugal juicer ④ **AT265**

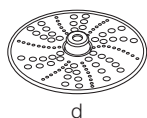

d



c

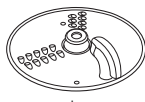

b

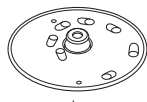

h

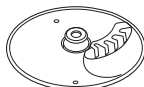

g

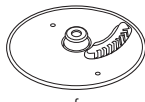

f

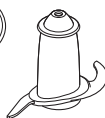

a



e

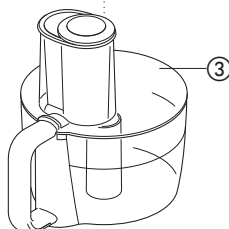

③

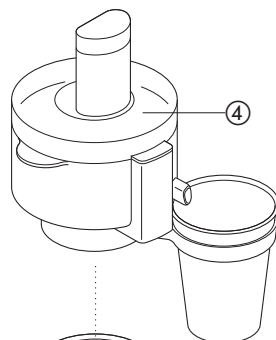

④

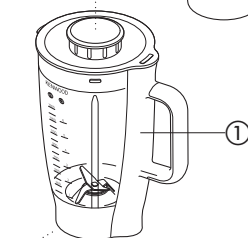

①

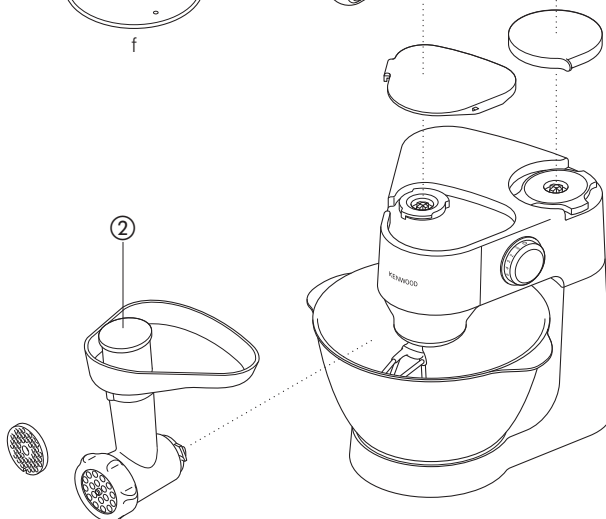

②

cleaning and service

care and cleaning

- Always switch off and unplug before cleaning.
- power unit
- Wipe with a damp cloth, then dry.
 - Never use abrasives or immerse in water.
- bowl, tools, splashguard, removable guard on dough hook
- Wash by hand, then dry thoroughly or wash in the dishwasher.
 - Never use a wire brush, steel wool or bleach to clean your stainless steel bowl. Use vinegar to remove limescale.
 - Keep away from heat (cooker tops, ovens, microwaves).

service and customer care

- If the cord is damaged it must, for safety reasons, be replaced by KENWOOD or an authorised KENWOOD repairer.
- UK
- If you need help with:
- using your appliance
 - servicing or repairs (in or out of guarantee)
- ☎ call Kenwood Customer Care on **023 92392333**.
- Have your model number ready** - it's on the underside of the mixer.

● spares and attachments

- ☎ call 0844 557 3653.
- other countries
- Contact the shop where you bought your appliance.

- Designed and engineered by Kenwood in the UK.
- Made in China.



IMPORTANT INFORMATION FOR CORRECT DISPOSAL OF THE PRODUCT IN ACCORDANCE WITH EC DIRECTIVE 2002/96/EC.

At the end of its working life, the product must not be disposed of as urban waste. It must be taken to a special local authority differentiated waste collection centre or to a dealer providing this service.

Disposing of a household appliance separately avoids possible negative consequences for the environment and health deriving from inappropriate disposal and enables the constituent materials to be recovered to obtain significant savings in energy and resources. As a reminder of the need to dispose of household appliances separately, the product is marked with a crossed-out wheeled dustbin.

guarantee UK only

- If your machine goes wrong within one year from the date you bought it, we will repair or replace it free of charge provided:
- you have not misused, neglected or damaged it;
- it has not been modified;
- it is not second-hand;
- it has not been used commercially;
- you have not fitted a plug incorrectly; and
- **you supply your receipt to show when you bought it.**

This guarantee does not affect your statutory rights.

recipe

carrot and coriander soup

ingredients

- 25g butter
- 1 onion chopped
- 1 clove garlic crushed
- 750g carrot cut into 1.5 cm cubes
(alternatively for a lighter soup use 600g carrot cut into 1.5 cm cubes)
- cold chicken stock
- 10-15ml ground coriander
- salt and pepper

method

- 1 Melt the butter in a pan, add the onion and garlic and fry until soft.
- 2 Place the carrot into the liquidiser, add the onion and garlic. Add sufficient stock to reach the 1.5 level marked on the goblet. Fit the lid and filler cap.
- 3 Blend on the pulse setting for 5 seconds for a coarse soup or longer for a finer result.
- 4 Transfer the mixture to a saucepan, add the coriander and seasoning and simmer the soup for 30 to 35 minutes or until cooked.
- 5 Adjust the seasoning as necessary and add extra liquid if required.



Head Office Address:
Kenwood Limited, New Lane, Havant, Hampshire PO9 2NH, UK
www.kenwoodworld.com
Designed and engineered by Kenwood in the UK
Made in China